

MANUAL

New Version
850 V

User Manual for
Sunways Solar Inverters NT 6000, NT 5000,
NT 4000 and NT 2600

SOLAR INVERTERS

User Manual for Sunways

Solar Inverters NT 6000, NT 5000, NT 4000
and NT 2600

List of Contents

1.0 General information

1.1	Safety information	93	General safety information
		94	Opening the unit
1.2	Sunways Solar Inverters NT 6000, NT 5000, NT 4000 and NT 2600	95	Scope of supply
			Inspecting the delivery
		96	Integration into the PV system
			Design of the PV generator
		97	Standard components of a PV system
		98	Protection concept

2.0 Information on installation

2.1	Safety information		
		100	Electrical safety
			Mechanical safety
		101	Information on cleaning
2.2	Basic configuration		
		102	Fixed voltage setting
		103	Country selection
2.3	Installation		
		105	Requirements on the place of installation
		106	Electrical connection and cable entry
		107	Grid connection

	109	PV generator connection
	111	Important Information
	112	Communication connections
	114	Connection of the alarm relay
	116	Connecting the sensors
2.4 Commissioning	118	Switching the solar inverter on and off
	120	Configurations
3.0 Information on operation		
3.1 Monitoring and diagnosis	125	Display
	126	Data memory
3.2 Sunways NT Monitor software	127	General information
	128	Initialising the remote modem
	129	Connection and circuitry options
	134	Configuring the interface cables
	136	Data acquisition
	137	Operation
3.3 Fault indications	139	Fault indications
3.4 Fault diagnosis	143	Fault display, causes and remedies

3.5	Warranty terms and conditions	150	Warranty terms and conditions
4.0	Appendix		
4.1	Subject and abbreviation index	153	Designation and description
4.2	Function and information index	155	Functional principle and explanations
		158	Block diagram of the Solar Inverter in the PV system
		160	Technical data
		164	Tyco Solarlok connectors
		166	Conformity and safety declarations
		170	General exclusion of liability
			Rights
			Registered trademarks

1.1 Safety information

The User Manual contains safety hints. These are identified by a triangle with an exclamation mark.



General safety information

All safety hints contained in this section and throughout the User Manual must be complied with at all times to guarantee the user's safety. The described product must not be operated if any mechanical or electrical components are defective.

Before commissioning the system, we strongly advise you to carefully read and heed the instructions! Non-compliance can have serious consequences, for example damage to the unit or other property or physical injuries with possible loss of life.

The solar inverter must be installed by a trained, qualified electrician. The electrician must be approved by the competent electricity board (EB). The relevant tasks to be carried out are identified by an additional adjacent symbol in the respective chapter headings.



Opening the unit

Before opening the cabinet, the unit must always be disconnected from the grid and from the PV generator.

The unit continues to conduct a hazardous voltage internally and at the connection sockets for ca. five minutes after disconnecting from the PV generator. The energy storage capacitors are only fully discharged after this period.

After disconnecting the unit from the grid and from the PV generator, you must wait at least five minutes before opening the unit.

1.2 Sunways Solar Inverters NT 6000, NT 5000, NT 4000 and NT 2600

Scope of supply

- Sunways Solar Inverter in the NT series
- Installation frame
- Manual, setup, warranty card, CD-Rom with software
- 2 pairs of Tyco Solarlok connectors

Inspecting the delivery

The condition of our products is checked prior to delivery. Although our products are carefully packed in recyclable packing, transportation damages can still occur. These are generally the transport company's responsibility.

Please inspect the delivered solar inverter thoroughly!

If you discover any damage to the packing or the solar inverter, please inform the transport company immediately. Your specialist dealer will be glad to assist you if required. Any damages must always be reported to the transport company in writing seven days after receipt of the goods at the latest.

EN

Integration of the solar inverter into the PV system

Design of the PV generator

The technical data of the selected PV generator must be within the specification of the solar inverter (see Technical Data). Incorrect dimensioning can cause losses in yield and destruction of the unit. The Sunways NT Sundim design program for the PV generator may be helpful. Sunways NT Sundim is available on the enclosed CD or from our website, www.sunways.de.

Please take account of the following points before planning your system:

- Check your PV generator for soiling ca. every three years. This occurs particularly at the lower edge of the modules and forms a film, which even heavy rain cannot wash away. Decreases in yield can be prevented by cleaning with a wet cloth or a brush.
- Avoid shading of individual modules or solar cells in your system. This can result in heavy losses in yield.
- Pay attention to the skyward alignment of the modules. You will obtain maximum yield in Central Europe with a module inclination of 30° to the horizontal and a direct southerly alignment of the generator field.
- The output of the cells decreases as the module temperature increases. Install your PV generator with adequate rear ventilation.

Standard components of a PV system

Depending on the recommendations of your electrician, your PV system will consist of the following components:

Standard components of the PV system

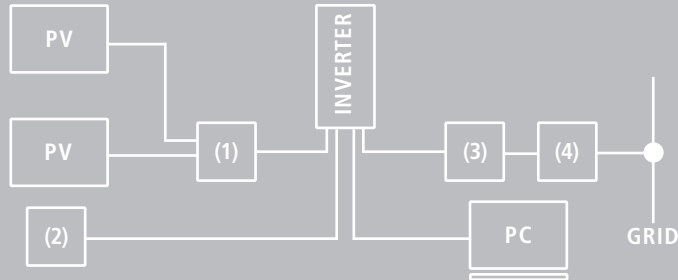

- (1) PV generator switch
- (2) Irradiation sensor with integrated temperature sensor
- (3) Mains fuse
- (4) Energy meter

PV generator switch:

Designed as DC load break cut-out to cut off the PV generator from the solar inverter.

Dimensioning: min. 900 V, ≥ 16 A

Grid connection:

3-phase (Feed-in: 1-phase; grid monitoring: 3-phase)

Protection concept

The following parameters are monitored continuously and in parallel by the micro-controller and displayed on the screen:

- DC overvoltage (Fault 3)
- Frequency error (Fault 4)
- Overheating (Fault 5)
- Grid undervoltage, 1-phase (Fault 6)
- Grid overvoltage, 1-phase (Fault 7)
- Grid undervoltage, 3-phase (Fault 8)
- AFI error (Fault 9)
- Insulation error (Fault 10)
- DC feed (Fault 11)
- Isolated operation (Fault 12)
- Grid overvoltage, 3-phase (Fault 13)
- Surge error (Fault 14)
- Grid voltage 10-minute average value > 10 % U_{NOM} (Fault 15)

In the event of a fault, the conversion is blocked immediately and the grid relay is isolated. An alarm relay with floating output is activated (not for Fault 6).

In addition, the following protective devices are provided on both grid and PV generator side:

- Grid-side varistors
Protect the power semiconductors from high-energy, time-limited voltage spikes on the grid and provide for a reduction of energy in the throttle in the event of grid disconnection.
- Generator-side varistors
Thermally monitored varistors provide protection against atmospheric overvoltages (e.g. due to remote strikes during storms).

2.1 Safety information



Electrical safety

Before opening the cabinet, the solar inverter must be disconnected from the grid and from the PV generator.

The solar inverter conducts a hazardous voltage internally and at the connectors of the PV generator for approx. five minutes after isolation from the PV generator and the grid. The energy storage capacitors are only fully discharged after this period.

After disconnecting the solar inverter from the grid and PV generator, you must wait at least five minutes before opening the solar inverter.

Mechanical safety

During installation, make sure that the cables or connection lines fitted to the solar inverter are securely laid and that suitable mechanical cable supports (cable ducts etc.) are used.



Information on cleaning

Before cleaning, disconnect the system from the power grid by opening the grid breaker (main fuse) and open the DC switch on the PV generator, in order to exclude the danger of electric shocks.

Use a soft, dry cloth to clean the system. Never use corrosive, solvent-containing or abrasive cleaners or polishes.

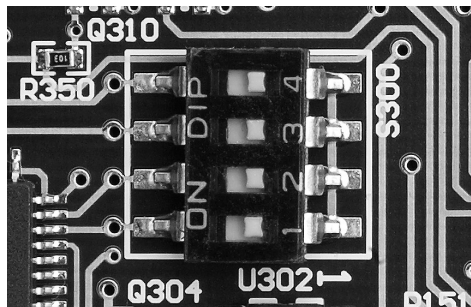

Country selection

Please note that a different device configuration is required to operate Sunways Solar Inverters in different countries. You can make the relevant setting with DIP switch S300 beneath the display panel.



(Fig.) DIP switch S300 for country selection

EN

Country	switch position	modification
Germany		
Spain		<ul style="list-style-type: none">· Disconnect interval after power failure 3 minutes· 1-phase grid monitoring

2.3 Installation

The solar inverter must be installed by a trained, qualified electrician. A special tool is necessary for installation. Please read this chapter very carefully.

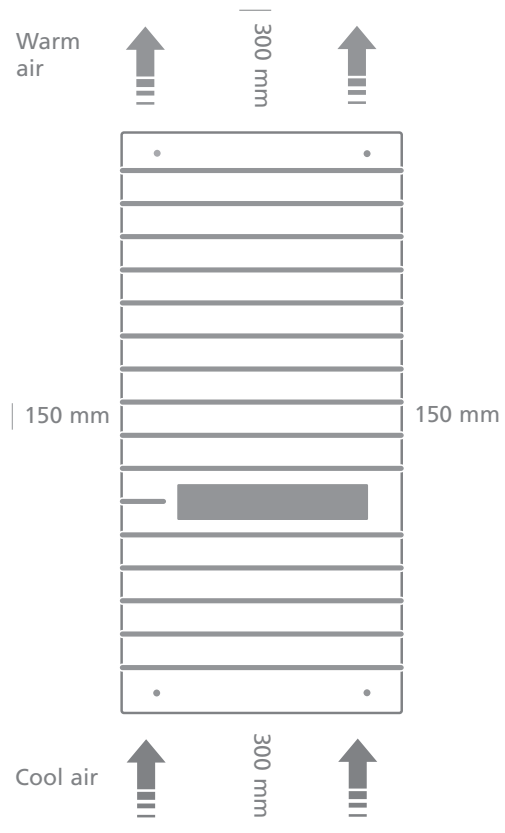

(Fig.) Minimum distances that must be kept clear around the solar inverter

Requirements on the place of installation

· Mechanical bearing capacity

During installation please bear in mind that the solar inverter weighs 26 kg. The installation base must be firm and capable of continuously bearing the weight.

· Thermal interaction

The installation base must consist of flame-retardant material (e.g. no wood or plastic in the base; concrete and brickwork are suitable), as the heat sink emits temperatures up to max. 85°C.

A minimum distance of 300 mm must be maintained above and below the cabinet, and 150 mm on right and left from other units, cabinets, ceilings, cable ducts etc..

The solar inverter must be installed vertically, so as not to hinder adequate free convection.

Several solar inverters must not be installed on top of each other, so as to prevent reciprocal heating.

If installing the solar inverter in a switch box, ensure adequate heat dissipation.

The ambient temperature must not fall below or exceed -25°C or $+40^{\circ}\text{C}$.

The solar inverter should not be exposed to direct solar irradiation, so as to protect it from unnecessary external heating.

· Protection from damp and foreign bodies

The IP54 high protection class permits installation both inside and in roofed outdoor areas, but the solar inverter must not be exposed to direct rain.

Make sure that the solar inverter cannot be exposed to foreign bodies (deposits of dust and dirt). In order to avoid losses in yield, the unit should be regularly freed from dust deposits.

Electrical connection and cable entry



For installation, please observe the instructions in the «Setup» leaflet!

If the solar inverter is fixed to the installation frame, the electrical connection can be led through. The unit may only be opened by a qualified electrician. The cabinet cover must first be released and removed.

The SUB-D connector for the RS 232 connection is located on the bottom, as well as inlets for cables:

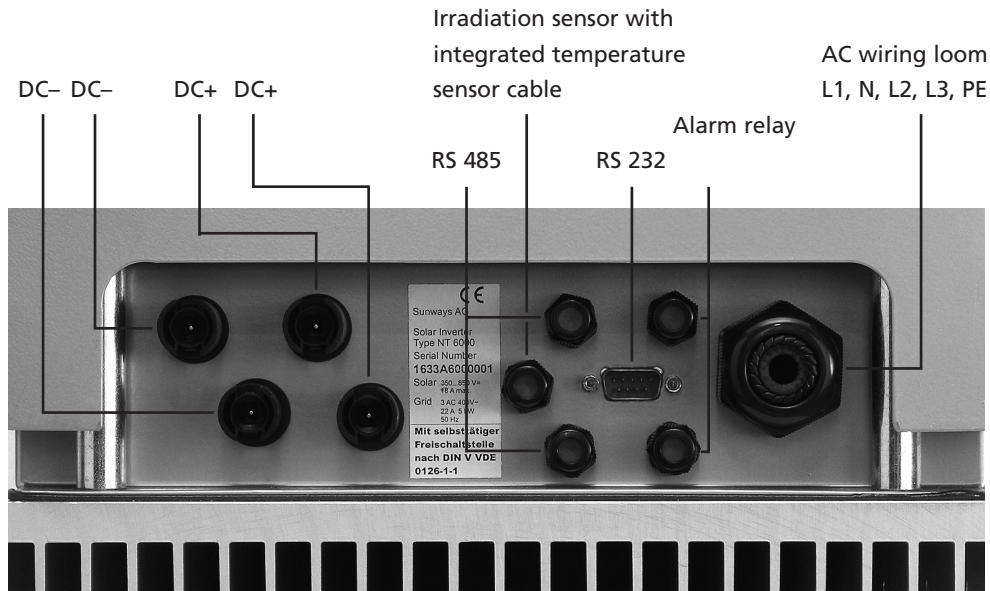

(Fig.) Inlets on the unit underside

Grid connection



The grid connection of the solar inverter must have 5 wires (L1, N, L2, L3, PE). Cable cross-sections of $5 \times 4 \text{ mm}^2$ are recommended.

The solar inverter is connected to the supply grid via the circuit board terminals inside the unit.

We recommend a 3 x 25 A safety cutout for devices NT 6000, NT 5000 and NT 4000 and a 3 x 16 A safety cutout for device NT 2600 as grid protection element in the grid feed-in direction. No consumption units must be connected to the feed line from the solar inverter to the automatic cut-out. The solar inverter only feeds in via terminal L1. Please always observe the connection configuration. Incorrect configuration can result in destruction of the unit.

EN

Three-phase grid connection distributed over three units

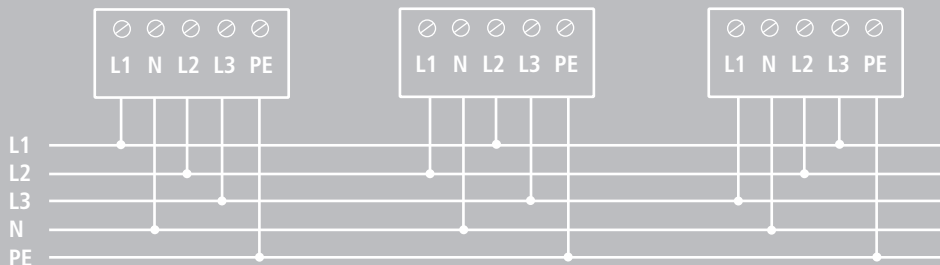

If several solar inverters are operated in parallel, the feed-in phase L1 of the unit must be evenly distributed over grid phases L1, L2 and L3 (see Fig. page 107).

You must use adequately dimensioned cable cross-sections in order to avoid a considerable increase in the grid impedance between the domestic distribution and the solar inverter. The terminal range of the AC terminals is 0.5 to 6 mm² for rigid cables and 0.5 to 10 mm² for flexible cables. With a high grid impedance, i.e. with a long line or too small a cross-section, the voltage increases at the grid terminal during feed-in.

If the terminal voltage exceeds the permissible value, the solar inverter is disconnected from the grid. In the case of poorly designed electric grids and high PV output, this can also result in repeated switching off and on of individual solar inverters.

Carefully perform the following steps:

- **Check that there is no voltage before introducing the supply main into the unit.**
- Lead the 5-core AC cable (outer diameter 9 – 17 mm) through the M32 threaded cable gland.
- Connect cables L1, N, L2, L3 and PE to the relevant circuit board terminal with the help of a slot-head screwdriver



(Fig.) Circuit board terminal for fixing the grid cable

- Tighten the M32 screw connection, so that the cable cannot exert any mechanical force on the circuit board terminal.

PV generator connection



· Preparation

Execute the DC cabling according to your electrician's system dimensioning. Check each PV string for correct functioning by performing a no-load voltage current and short-circuit current measurement.

Check the rating plate on the solar inverter to ensure that the inverter is approved for the maximum PV generator voltage.

To achieve the necessary protection against hazardous contact voltage during the installation of PV systems, the positive and negative conductors must be kept separate from the ground potential (PE).

Contactable, conductive parts of the PV generator (e.g. metal frame, supporting structure etc.) must be earthed (connected to PE).

Check that the generator is free from ground faults.

Make the electrical connection to the solar inverter.

· Connection

The PV generator is connected via the externally accessible, shock-proof Tyco Solarlok connectors, which are enclosed with the delivery. The Tyco Solarlok connectors are designed for a cable cross-section of 4 mm² and must be crimped (see chapter 4.2 «Tyco Solarlok connection»).

Connect the two right DC female connectors with «+», the two left DC female connectors with «-» of the PV generator. Always ensure the correct polarity!

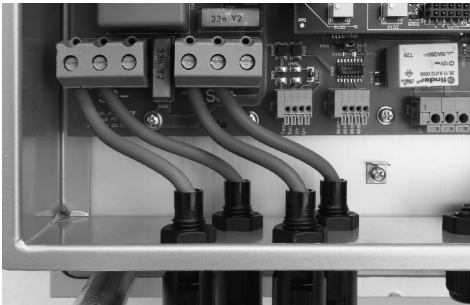

(Fig.) PV generator connection via Tyco Solarlok connector

Important information



- The direct PV generator voltage is available internally after connecting the PV generator to the solar inverter via the DC connectors and switching on the PV generator switch!
 - Please note that the input capacitors are still charged even after switching off the PV generator switch or removing the PV generator plug connection!
 - After disconnecting the AC and DC side, the solar inverter still conducts voltage for up to ca. five minutes!
 - Therefore, wait for at least five minutes until the internal voltage has dissipated. Then you can work on the terminals!
Note chapter 2.1 «Safety information»!
- The DC voltage can be up to 850 V. The unit may only be opened by a qualified electrician!
 - Always disconnect the PV generator side first by opening the PV generator switch, and then the grid connection by isolating the relevant mains fuse!
 - If you do not have a PV generator switch in your PV system, you must disconnect the grid connection first of all by isolating the relevant mains fuse. However, an error will be entered in the error memory of the solar inverter!
 - Disconnection of the PV generator by removing the Tyco Solarlok DC connectors must never be performed under load. In the event of non-compliance, the connectors could be damaged by a strong electric arc. In this case, the relevant connectors must be replaced!

Communication connections



Via the communication connections (interfaces), operating data can be retrieved from the data memory with an external computer and specific operating settings made. Several communication interfaces are available: RS 232 and RS 485.

The standard communication interface is the RS 232 interface, which is installed in all current PCs and notebooks. This interface allows you to establish contact with your PC immediately, using a connecting cable. The use of more than one solar inverter or cable lengths of more than 25 m requires the use of the RS 485 interface.

The RS 232 interface is connected directly to the outside of the housing via a SUB-D connector. The RS 485 interface is connected via the circuit board terminals and the corresponding M12 threaded cable glands in the housing.

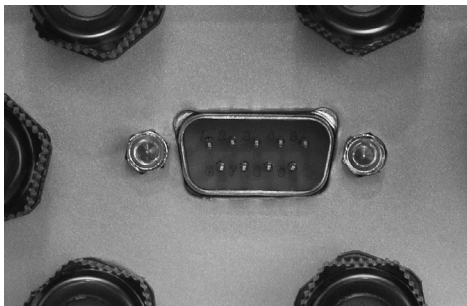

(Fig.) SUB-D connector for RS 232 connection

Attention: RS 485+ and RS 485- are duplicated. This means that the cable entry and exit are additionally clamped.

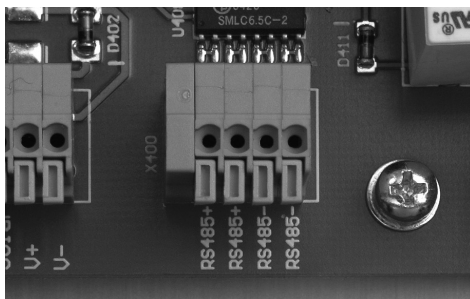

(Fig.) Connection block for RS 485

· **Connection RS 485**

Remove the cover of the solar inverter before connecting an interface cable. Note chapter 2.1 «Safety information»!

The necessary cable terminal block (X400) with the RS 485+, RS 485+, RS 485- and RS 485- connections is located in the lower section of the board (see fig. page 112). Note the following terminal configuration:

RS 485: RS 485+, RS 485+, RS 485-, RS 485-

Use a small screwdriver. Press the orange terminal. The terminal will open.

Insert the cable stripped to a minimum of 11 mm into the respective terminal hole.

Release the screwdriver. The cable is fixed in the connection.

Once again, check that the cable connection is firmly located.

Seal the unrequired cable glands by placing a spare piece of cable in the gland hole and tightening with the screw clamp.

Please note chapter 3.2 «Sunways NT Monitor software».

· **RS 232 connection**

The RS 232 interface is externally accessible via the SUB-D connector.

Please note chapter 3.2 «Sunways NT Monitor software».

Connection of the alarm relay



Sunways Solar Inverters are equipped as standard with an alarm relay with floating output. The relay is designed as a make contact and is activated in the case of all faults reported by the unit (not for Fault 6). This guarantees quick and reliable indication of possible faults in the PV system. In the case of PV systems with several solar inverters, the individual relays can

be parallel-connected and connected via a joint signal light.

· Connection

Remove the housing of the solar inverter before connecting the status signal relay. Note chapter 2.1 «Safety information»!

The necessary terminal block with the connections «S-» and «S+» is located on the board at the bottom right (X402). Note the following terminal configuration:

Parallel connection of the alarm relays of several solar inverters

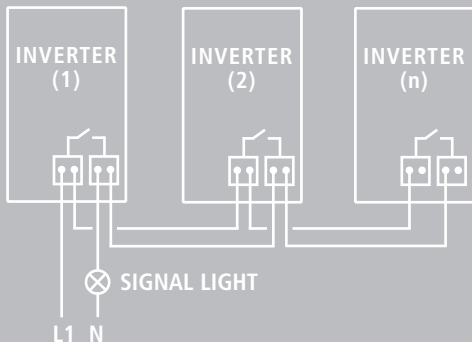

Terminal configuration for the alarm relay

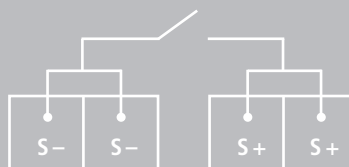

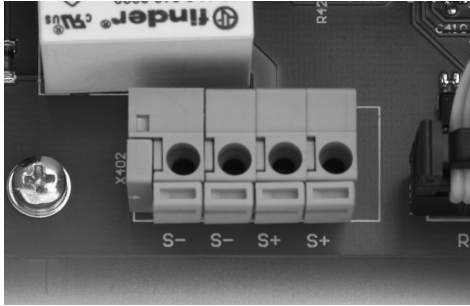

(Fig.) Connection of the alarm relay

Important information: The alarm relay is designed for 230 V / 2 A. Higher outputs / voltages can result in destruction of the relay. The connected signal input must have separate fuse protection!

Using a small screwdriver, press the orange terminal. The terminal will open. Insert the minimum 11 mm stripped cable into the respective terminal hole. Loosen the screwdriver. The cable is fixed in the connection. Once again, check that the cable connection is firmly located.



The terminals are designed for a cable cross-section of 0.2 mm² to 1.5 mm². Please also take account of the power consumption of the connected signal input when dimensioning the cross-section!

Connecting the sensors



· Optional irradiation sensor

The optional addition of an irradiation sensor (type Si-01TC-T from Ing.-Büro Mencke & Tegtmeier) with integrated PT-100 temperature sensor for temperature measurement enables recording of the irradiation data and the corresponding module temperature in the cycle of the internal data memory.

This additional measuring unit helps with analysis of the system. On the basis of the values, possible errors in the PV generator, such as e.g. shading or failure of solar cells, can be detected.

For demonstration purposes, the irradiation sensor and the corresponding data can be used to show how a PV system functions. In conjunction with the Sunways NT Monitor visualisation software, the stored data can be displayed.

Before you connect an irradiation sensor, you must remove the cover of the solar inverter. Please note that the inputs and outputs are not short-circuit resistant. Note chapter 2.1 «Safety information»!

The optional irradiation sensor with temperature probe is connected to cable terminal block X401 in the lower section of the board.

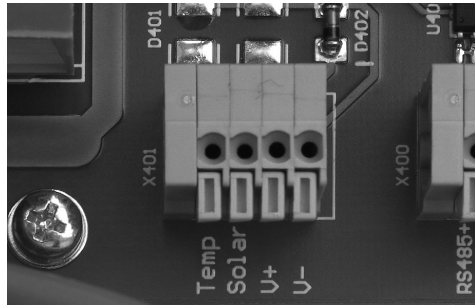

(Fig.) Connection block for the irradiation sensor

Configuration of the cable terminal block:

Temperature sensor

measuring signal: Temp

Solar radiation

measuring signal: Solar

Positive supply, 5V: V+

Supply, GND: V-

Using a small screwdriver, press the orange terminal. The terminal will open.

Insert the cable stripped to a minimum of 11 mm into the respective terminal hole.

Loosen the screwdriver. The cable is fixed in the connection.

Once again, check that the cable connection is firmly located.

2.4 Commissioning

Connect the solar inverter internally via the ground cable (yellow-green) to the cabinet cover. See also Setup, step 7.

Put the cabinet cover on.

Screw it down tightly with the four screws on the front.

Do not place any objects (e.g. this manual) on the cabinet of the solar inverter. Free ventilation behind the solar inverter must be able to take place unimpeded.

If the unit is mounted outdoors, please ensure proper sealing of the threaded cable glands and precise positioning of the housing cover as well as the protective cover of the SUB-D connector, if this connection is not configured.

Switching the solar inverter on and off

· Switching on

When the solar inverter is mechanically installed and connected to the electrical cables, the unit can be commissioned as follows:

Switch the grid connection on through the external safety cutouts.

Switch the PV generator voltage on by closing the PV generator switch. The solar inverter will start up with adequate PV power. If the PV input voltage is high enough, the solar inverter will begin operation and feed the solar energy into the electrical grid. You can see the operation on the display. The current feed-in power is shown here.

The solar inverter is supplied by the grid. With adequate PV output, the solar inverter switches on automatically. Appropriate switch-on and switch-off thresholds are fixed for this purpose.

· **Switching off**

Disconnect the PV generator side first by opening the PV generator switch, and then the grid connection by isolating the relevant mains fuse.

If your PV system does not have a PV generator switch, you must disconnect the grid connection first of all by isolating the relevant mains fuse. When you do this, an error will be entered in the error memory of the solar inverter.

If the solar inverter is to be completely disconnected (e.g. removal) from the PV system, reconfigured or extended, the cabinet cover must be removed. Note chapter 2.1 «Safety information»!



Open the main switch for the PV DC voltage and the mains fuse as described above. After a waiting period of at least five minutes, the solar inverter will be voltage-free.

Disconnection of the PV generator by removing the Tyco Solarlok connectors must never be performed under load. In the event of non-compliance, the connectors could be damaged by a strong electric arc. In this case, the relevant connectors must be replaced!

Remove the cabinet cover.

Check that the grid connection terminals are voltage-free.

Configurations

The solar inverter is basically configured with the Sunways NT Monitor program, using a laptop or PC (see enclosed CD).

Please read the chapter 3.1 «System Monitoring and Diagnosis» and 3.2 «Sunways NT Monitor».

However, language setting, LCD contrast and total energy offset (only to be used in the event of replacement) must be configured directly on the unit. If you wish to configure the solar inverter without an external laptop or PC, or to change the language setting, please follow the instructions below:



Direct configuration of the solar inverter occurs in operation!

Please note that the unit is under DC voltage for configurations via the keys. Danger to life!

Please observe all essential regulations for «Working under voltage»!

This is the only exception for which work may be performed on the open unit under voltage!

Remove the cabinet cover to carry out the configuration.

The following settings can be performed using the illustrated keys:

- Address of the solar inverter: address «1» is stored in the memory at the factory. In the case of several solar inverters, consecutive numbering must be set. For three solar inverters e.g. the addresses «1», «2» and «3».
- Date
- Time
- Language (German, English, French, Spanish, Italian)

EN

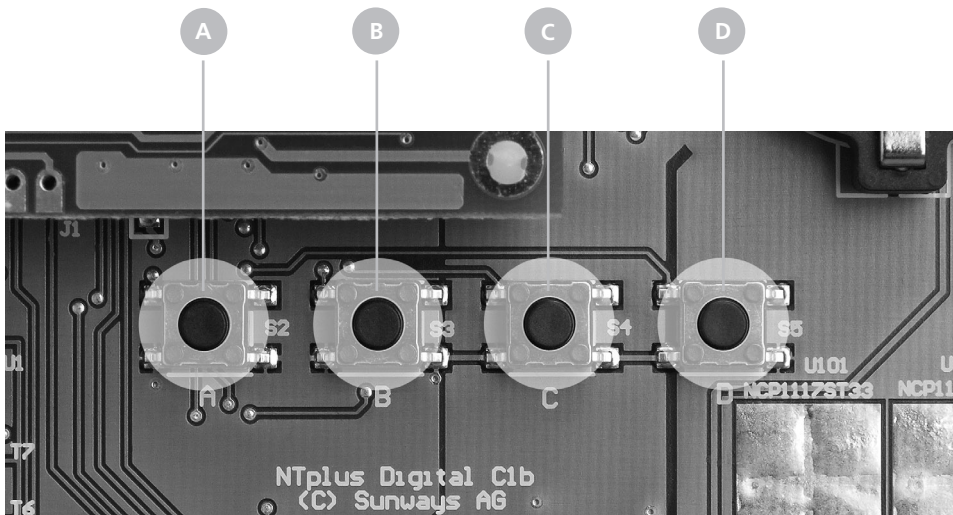

(Fig.) The setting keys are located beneath the display

Use insulating material to press the keys (e.g. a plastic rod). Avoid direct contact with the printed circuit board, so that the electronics cannot be damaged by electrostatic charging. Starting from the current

display on the screen, you can reach the next menu level with the D-key. The illustrated structure facilitates settings on the menu levels. Then save your settings by pressing the C-key.

Structure and menu levels for configuration

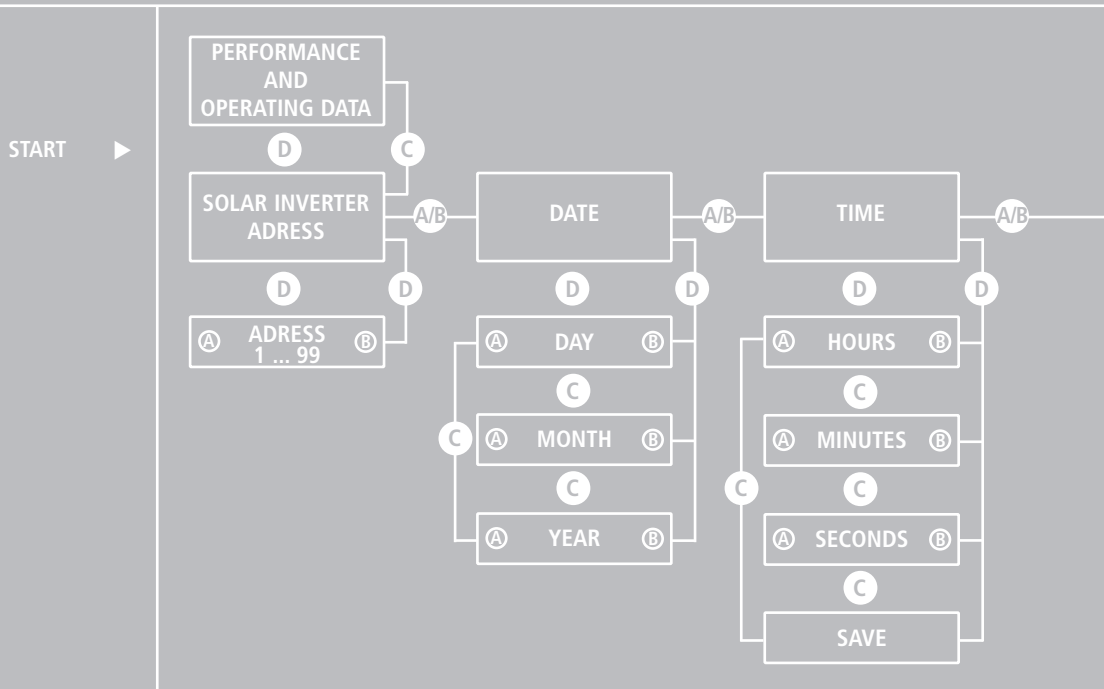

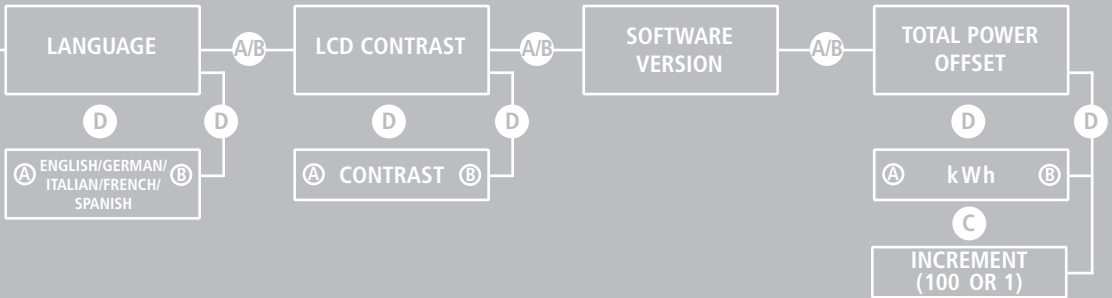

3.1 Monitoring and diagnosis

Display

The dot matrix LCD display is integrated into the cabinet of the solar inverter so that it is easily visible. The display consists of 16 characters and 2 lines. The top line 1 shows the current feed-in power of the solar inverter. The bottom line 2 outputs operating data. The data can be displayed in the German, English, French, Spanish or Italian language.

EN

Line 1	Current fed-in power	Power	kW
Line 2	AC voltage DC voltage Daily yield Total yield Irradiation * PV generator temperature * Time	U-AC U-DC W-DAY W-TOT SOLAR TEMP-PAN TIME	V V Wh kWh W/m ² °C

* if the optional irradiation sensor with integrated temperature sensor is connected

Data memory

Your solar inverter is equipped with an internal data memory as standard. This data memory provides you with a detailed view of the mode of functioning and the relevant values of your solar power supply at all times. You can access these data with the help of the NT Monitor software described below. The following measured values can be determined:

- DC voltage
- AC voltage and AC current (power calculation)
- Irradiation and module temperature (if a sensor is connected)
- Time and date

The following values are accumulated, stored and continuously overwritten:

- 15 minute values for AC current, DC and AC voltages, irradiation and temperature
- 500 times storage of 15-minute average values in the recirculating storage; storage depth: ten days on average, then overwriting of values

- Storage of accumulated daily work in Wh and of 40 daily values in the recirculating storage and successive overwriting of values
- Storage of accumulated monthly work in kWh and of 13 monthly values in the recirculating storage, then overwriting of values
- Storage of faults with max. ten values, then successive overwriting of values

Please note that all displayed data are displayed with a nominal measuring accuracy of maximum 5 per cent. The energy counter of your EVU should be used as absolute reference for the fed-in energy.

3.2 Sunways NT Monitor software

General information

The Sunways NT Monitor visualisation software was developed for PV system monitoring and configuration of the solar inverter using PC. It is contained on the enclosed CD and can also be downloaded free of charge on the Internet from www.sunways.de.

System prerequisites are:

- Intel Pentium from 100 MHz or higher
- Microsoft Windows 95/98/2000/NT
- At least 6 MB free hard disk storage space
- At least 16 MB main memory
- VGA monitor with at least 800 x 600 (120 dpi) resolution

All measured values can be transferred to a PC and visualised with the Sunways NT Monitor software. Online, fault, minute, daily and monthly values are available.

For connecting to your PC, Sunways solar inverters in the NT series are equipped with the RS 232 and RS 485 interfaces as standard. In the case of larger distances between PV system and PC, the data can also

be transferred via a modem. We recommend using two external analogue modems made by ACER. If other modems are used, the functional reliability cannot always be guaranteed.

The modem (remote modem) installed in the solar inverter must be initialised prior to installation with the help of the Sunways NT Monitor software. Note the "Help" function in the program in this regard.

The second modem (local modem) is connected to the RS 232 interface of your PC. This modem must not be initialised.

Different interface cables are required, depending on the type of connection. These are included in the accessories.

Up to 99 solar inverters can be monitored and read out by means of a connection via the RS 485 interface.

If the data are read out via the RS 485 interface and converted to RS 232 with an interface converter, we recommend the converter type «I-7520 Converter»

from ICP-Deutschland, (available from your specialist dealer), which will guarantee reliable data transfer.

The addresses of the solar inverter must be input with the Sunways NT Monitor software. Alternatively, see chapter 2.4 «Commissioning, configurations».

Initialising the remote modem

If a remote modem is installed in the solar inverter, it must be initialised using a PC and the Sunways NT Monitor software.

- Attention! Do not initialise the local modem which is intended for use on the PC!
 - The remote modem is now initialised so that it automatically accepts a connection after two rings and connects at 9600 Baud.
- Connect the powered remote modem to the PC via the COM port. Use the interface cable provided with the modem for this purpose. Start the Sunways NT Monitor and set «Acer Modem» under the «Settings/Remote Modem» menu.
 - Click «Perform initialisation» and wait until the scroll bar has come to an end. The modem can now be switched off and connected to the solar inverter via the RS 232 interface.

Connection and circuitry options

(1) Individual PV system with maximum distance of 25 m between solar inverter and PC



Connection to the PC via RS 232

SUB-D connector

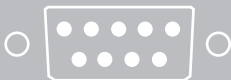

An individual solar inverter can be connected directly to the PC via the external RS 232 interface on the bottom of the device.

Jumper JP400: open

(1) An individual solar inverter can be read out using this connection, unless the distance from the PC exceeds a distance of 25 m. For this purpose, cable type 1 is connected with the solar inverter via the SUB-D connector and connected to a PC. Jumper JP400 must be in open position.

(2) Individual PV system with modem for remote inquiry



Connection to modem via RS 232

SUB-D connector

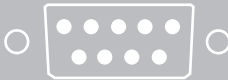

When connecting an individual solar inverter, the remote modem is connected directly to an external interface converter (IC) RS 232 at the bottom of the solar inverter.

Jumper JP400: open

(2) For installation of the remote inquiry of an individual solar inverter, the RS 232 signal can be conducted directly from the solar inverter to the remote modem via the SUB-D connector. Cable type 2 is used for this purpose. A cable length of 25 m should not be exceeded for the RS 232 connection between solar inverter and modem. Jumper JP400 must be in open position.

(3) PV system for 2 to 99 solar inverters with interface converter (IC) RS 485 / RS 232

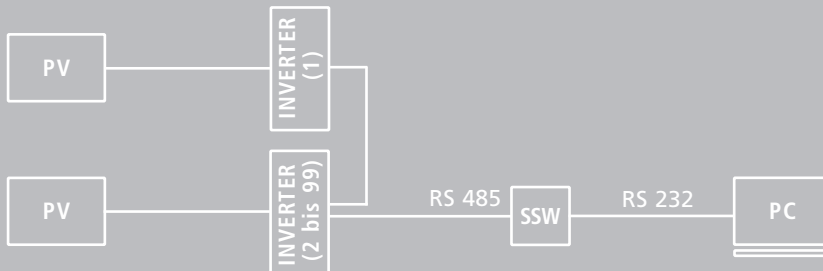

Connection to PC via RS 485 / RS 232

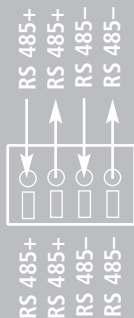

In order to connect several solar inverters to a PC, the RS 485 signal is looped through from inverter to inverter, until it is led into the interface converter. From here, the RS 232 signal is conducted to the PC. Jumper JP400 is connected to the solar inverter that is furthest away from the interface converter. It must be open for all other solar inverters.

Stripped length: 11 mm
Jumper JP400: see above

(3) Up to 99 solar inverters can be connected together and read out using this connection. In this case, there is a maximum cable length of 500 m between

the interface converter and the furthest solar inverter. The individual solar inverters are connected together via the RS 485 interface.

The signal is looped through all units. Two «RS 485+» terminals and two «RS 485-» terminals are located on each terminal block. This means that the signal can be led into the solar inverter at one terminal and out of the solar inverter at the other terminal. The RS 485 signal is led out of the last solar inverter in the series into the interface converter using the following configuration: «RS 485+» to «DATA+» and «RS 485-» to «DATA-».

The interface converter generates an RS 232 signal. It is connected to the PC with the standard modem cable type D. Jumper JP400 must be closed at the solar inverter that is furthest away from the interface converter. For all other solar inverters it must be open. An address must be allocated, to enable identification of the individual solar inverters. Note chapter 2.4 «Commissioning, configurations».

(4) PV system for 2 to 99 solar inverters with interface converter (IC) and modem for remote inquiry

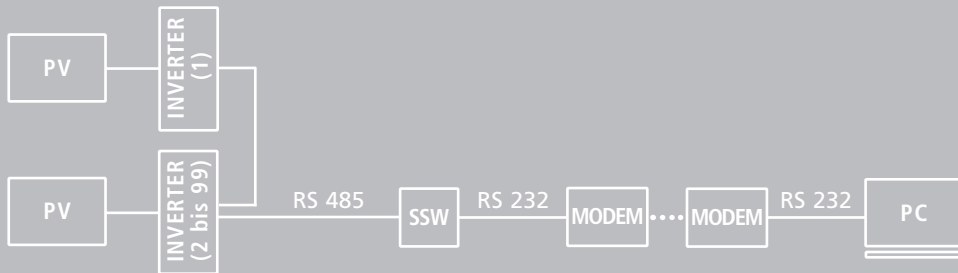

Connection to modem via RS 485 / RS 232

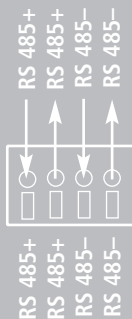

In order to connect several solar inverters to the remote monitoring, the interface converter is connected directly to a modem via RS 232. Jumper JP400 is connected to the solar inverter that is furthest away from the interface converter. It must be open for all other solar inverters.

Stripped length: 11 mm
Jumper JP400: see above

(4) If several solar inverters are to be connected to the remote inquiry, then the individual inverters are connected together by means of the RS 485 signal, as when reading out several units locally. This signal is converted by the interface converter into the RS 232 signal, from where it is led to the modem using cable type 3. Jumper JP400 must be closed at the solar inverter that is furthest away from the interface converter. For all other solar inverters it must be open. An address must be allocated, to enable identification of the individual solar inverters. Note chapter 2.4 «Commissioning, configurations».

Configuring the interface cables

Cable type 1

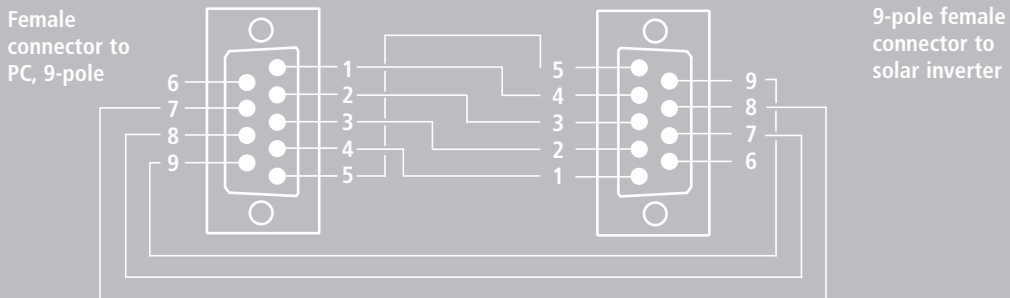

Cable type 2 (Provided in the scope of supply of the «Acer» modem)

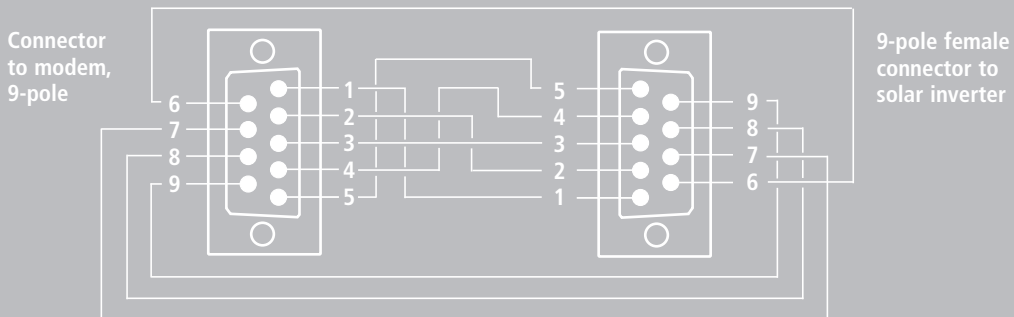

Cable type 3

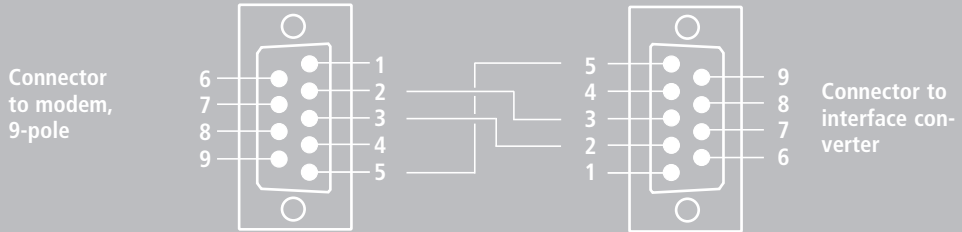

Jumper JP400 in the Sunways Solar Inverter

Please check the correct position of jumper JP400, depending on your selected communication circuit. This jumper is located above the RS 485 communication connection in the lower section of the board.

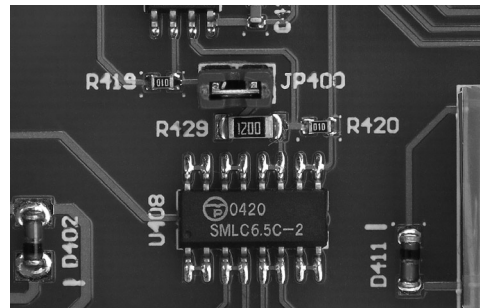

(Fig.) Position of jumper JP400

Data acquisition

· Online values

DC voltage (U_DC), AC voltage (U_AC), AC current (I_AC), date, time, AC power, module temperature, module irradiation, «fed-in today», «fed-in since commissioning», error.

· 15 minute values

DC voltage (U_DC), AC voltage (U_AC), AC current (I_AC), date, time, temperature, irradiation, «fed-in in 15 minutes», accumulated daily total of all 15 minute average values.

Representation as graphic or print; Option of saving as bitmap; Fade-in of graphics possible. Individual solar inverters can be called up with the scroll menu.

· Daily values

Date and daily energy in the solar inverter.

Representation as graphic or print; Option of saving as bitmap; Zoom-in of graphics possible. Individual solar inverters can be called up with the scroll menu.

· Monthly values

Date in the solar inverter, fed-in since commissioning and monthly energy.

Representation as graphic or print; Option of saving as bitmap; Zoom-in of graphics possible. Individual solar inverters can be called up with the scroll menu.

· Fault data

Date, time and type of fault (for the last ten faults)

· Calendar

Date and time in the solar inverter

· Modem

Selection of the modem type and input of the address signal

If required, detailed information on Sunways NT Monitor can be found under the «Help» menu item in the program software.

Operation

After installing the Sunways NT Monitor software on your PC, you can start the program. The word «Sunways» will now appear on your screen.

On the menu bar at the top, you will see the four menu areas «Program», «Data», «Settings» and «Help».

· **Setting menu**

To configure your solar inverter, open the «Settings» menu by clicking on it with the mouse, and click on the «Inverter» key. Enter the address number that you have defined for your solar inverter next to «Inverter». For example, the number «1» for one solar inverter. In the case of several units, select «all».

Then enter the desired date and time. The settings are transferred to the solar inverter by clicking on the «Make change» key.

If you are using several solar inverters and wish to make a change to the numbering, you can enter the old number of the

solar inverter in the top section of the right window half and the new number beneath it. The numbering is changed by clicking on the «Make change» key.

Exit the window with the «Close» key.

You can set the interface configuration with your PC by clicking on the «Connection» key.

By clicking on the «Remote modem» key, you can configure an optional modem (e. g. if you wish to retrieve data by remote inquiry).

· **Data menu**

In the «Data» menu, you can call up the current accumulated performance and energy of the solar inverter by clicking on the «Online» key.

You can display the data measured at 15 minute intervals by clicking on the «Minute values» key. The data and values are graphically visualised by clicking on the «Graphic representation» key.

You can call up «Daily values» and «Monthly values» in the same way, by clicking on the respective keys.

Exit the window with the «Close» key.
You will return to the «Settings» menu.

· **Help menu**

You will find further helpful information on operating the Sunways NT Monitor software in the "Help" menu.

3.3 Fault indications

Your solar inverter operates fully automatically and maintenance-free. However, should malfunctions occur due to external or internal causes, these will be indicated in the first line of the display. The available measured values will be provided in the second line.

Fault 3

· DC overvoltage

A maximum no-load voltage of 750 V is permitted for the PV generator. All components of the DC input are adequately dimensioned with a safety factor. If the threshold is exceeded, the solar inverter stops the feed-in and a «DC overvoltage error» is displayed.

Fault 4

· Frequency error

The solar inverter constantly monitors the grid frequency. If this is outside the range permitted by DIN V VDE V 0126-1-1, the solar inverter will stop the feed and «Fault 4» will be indicated.

Fault 5

· Overheating

Your solar inverter is designed for an ambient temperature of up to +40°C. When the maximum upper temperature threshold is reached, the feed-in is stopped. When the heat sink temperature has decreased, the solar inverter starts up again automatically.

Fault 6

· Grid undervoltage, 1-phase

Your solar inverter constantly monitors the voltage level of the feed-in phase. If the level falls below the minimum permissible limit value, the solar inverter stops the feed and only restarts when the voltage value rises above the minimum permissible limit value. If the voltage at L1 falls below 160 V, the solar inverter can no longer be supplied.

Fault 7

- **Grid overvoltage, 1-phase**

Your solar inverter constantly monitors the voltage level of the feed-in phase. If the level exceeds the maximum permissible limit value, the solar inverter stops the feed and only restarts it when the voltage value falls below the maximum permissible limit value.

Fault 8

- **Grid undervoltage, 3-phase**

Your solar inverter is equipped with intrinsically safe 3-phase grid monitoring according to DIN V VDE V 0126-1-1. The voltage level of phases L2 and L3 is constantly monitored. If the level falls below the minimum permissible limit value, the solar inverter stops the feed and only restarts it when the voltage value rises above the minimum permissible limit value.

Fault 9

- **AFI residual current**

The «AFI error current» fault occurs when an error current has occurred in the PV

system and the solar inverter has subsequently disconnected from the grid. The AFI residual current (insulation error, ground fault) is displayed if a residual current has occurred in the PV system and the solar inverter has subsequently disconnected from the grid. Ground faults are monitored on both the AC and DC side (universal current-sensitive FI). If this error message is displayed, the entire PV system must be checked for insulation errors. The mode of functioning complies with DIN V VDE V 0126-1-1.

Fault 10

- **Insulation error**

Before every activation, your solar inverter checks the PV system for possible ground faults or insulation errors. If such an error is detected, no feed occurs. The mode of functioning complies with DIN V VDE V 0126-1-1.

Fault 11

- **DC feed**

Your solar inverter constantly monitors the quality of the fed-in current. The solar inverter stops the feed as soon as an

increased DC component is detected in the fed-in current. The solar inverter only attempts to feed again after a reset (the next day).

Fault 12

· **Isolated operation**

Your solar inverter is equipped with high quality redundant grid monitoring according to DIN V VDE V 0126-1-1 and constantly monitors the grid. If one of the monitored phases drops out, or if the phase position between the individual conductors changes, the solar inverter stops the feed and only restarts when the error has been eliminated.

Fault 13

· **Grid overvoltage, 3-phase**

Your solar inverter is equipped with intrinsically safe 3-phase grid monitoring according to DIN V VDE V 0126-1-1. The voltage level of phases L2 and L3 is constantly monitored. If the level exceeds the maximum permissible limit value, the solar inverter stops the feed and only restarts it when the voltage value falls below the maximum permissible limit value.

Fault 14

· **Surge error**

Your solar inverter constantly monitors the quality of the AC grid. In the event of high voltage peaks in the grid, the solar inverter stops the feed and attempts to restart.

Fault 15

· **Grid overvoltage > 10 %**

If the voltage of the fed-in phase exceeded 253 V for a period of ten minutes, the solar inverter stops the feed and attempts to switch on again when the grid voltage is in the permitted range. The mode of functioning complies with DIN V VDE V 0126-1-1.

Fault 16

· **Control error**

Your solar inverter is equipped with a self-monitored microcontroller. If an error occurs in the control cycle, the solar inverter stops the feed and only switches on again when the error is eliminated.

Two LEDs, D302 and D304, are located on the control board in the solar inverter. These describe the current status of the solar inverter:

LED green	<input type="checkbox"/>	illuminated	Solar inverter operating in normal mode
LED red	<input type="checkbox"/>	off	
LED green	<input checked="" type="checkbox"/>	flashing	Solar inverter has detected an error
LED red	<input checked="" type="checkbox"/>	flashing	
LED green	<input type="checkbox"/>	off	internal error in the control
LED red	<input checked="" type="checkbox"/>	illuminated	

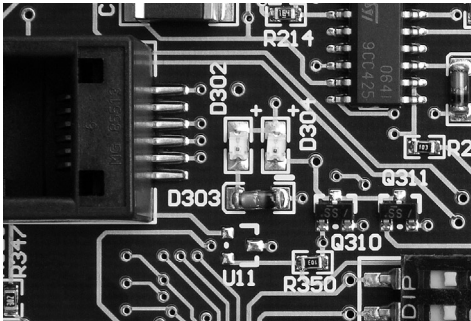

(Fig.) LED for functional check

3.5 Warranty terms and conditions

· **Warranty period**

The warranty period is five years from purchase of the solar inverter by the end user. Please complete the enclosed warranty card and return it to Sunways AG. Please keep the original invoice with the date of purchase in a safe place. This will be required as proof, in addition to the warranty card, in the event of a claim.

· **Conditions**

During the warranty period, the solar inverter will be repaired free of labour and material costs in Constance. Installation costs are borne by the customer, unless agreed otherwise. The completed warranty card must be sent to Sunways AG, Constance within seven days of purchase.

Please notify us of any warranty claims by telephone stating your name, address, telephone and serial number, and your email address if applicable. You will find the telephone number on the back of the manual.

Sunways AG must be allowed the necessary time to eliminate the defect. Sunways AG will endeavour to eliminate the defect within 14 days of receipt of the unit. If this is not possible, the customer will be informed of the reason and the time when the defect will be eliminated will be specified.

Please preserve the original packing, even after expiry of the warranty period. Carriers may only accept solar inverters in transport-safe original packing. Therefore, please inform us before collection if you have lost the original packing. We will gladly provide you with new packing for a charge.

· **Exclusion of liability**

Warranty claims and liability are excluded for direct or indirect damages due to:

- Interventions, modifications or attempted repairs
- Inadequate ventilation
- Force majeure (e.g. lightning strike, water damage, vandalism, fire, overvoltage, thunderstorms etc.)
- Inappropriate transport
- Non-observance of pertinent regulations or incorrect installation or commissioning
- Leakage of overvoltages from the varistors on the DC side on the PV generator

More extensive or other claims for direct or indirect damages, particularly claims for damages, including those arising from positive contract violation, are excluded, unless legally prescribed.

4.1 Subject and abbreviation index

Designation	Description
AC	Alternating Current: grid current
AFI, RCD	Operator protection in the event of residual currents AFI: Universal Sensitive Residual Current RCD: Residual Current Device
DC	Direct Current PV generator side of the solar inverter
EMC	Electromagnetic Compatibility
EB	Electricity Board
I_{NDC}	Current used to operate the solar inverter
IP	Identification of class of protection against external environmental influences (penetration of water and mechanical foreign bodies)
kW	Kilowatt
LCD	Liquid Crystal Display
MPP	Maximum Power Point

Designation	Description
Grid impedance	AC resistance of grid, impedance
P_{NDC} P_{NAC}	DC and AC rated power: Power which the inverters can permanently consume (DC) or emit (AC).
PT	Temperature sensor
PV	Photovoltaic
PV generator switch	DC load break switch to cut off the PV generator from the solar inverter
U_{NDC}	Voltage: specifies the normal operating voltage at which the solar inverter is operated

4.2 Function and information index

Functional principle and explanations

The electrical energy of the PV generator is buffered by a capacitive storage, from where it is fed into the public grid via a solar inverter synchronised with the grid, with an ideal phase angle of $[\cos \phi = 1]$.

A sinusoidal current with a very low harmonic distortion is injected into the public grid by the current injection inductor. This improves the grid quality.

Thanks to the HERIC® technology (patent applied for) in the self-commutated Sunways Solar Inverter, the hysteresis losses in the current injection inductors that occur in conventional solar inverters and the switching losses in the semiconductors are considerably reduced. Consequently, Sunways Solar Inverters achieve a peak efficiency during conversion. The concept of the Sunways Solar Inverter is completed by a rapid MPP control, which maintains the MPP point with a very high adaptation efficiency.

· DC and AC filters

The DC and AC filters are specially designed EMC filters, which are integrated as direct components on the board. They guarantee compliance with the EMC limit values on the AC side and on the PV generator side. High-frequency emissions are avoided by the filters on the PV generator side.

· Differential measurement

The generator current and the voltage are recorded via a current transformer and a differential measurement. The values are important input values for the regulation and setting of the correct working point.

· Solar inverter with HERIC® technology

The heart of the solar inverter with the power semiconductors serves for conversion of the current from direct into alternating current. Peak efficiencies are achieved, thanks to the HERIC® technology. The switching frequency (PWM) is 16 kHz.

· **Grid protection**

The grid protection is a powerful relay which ensures reliable grid disconnection in the case of error and for night switch-off. This relay fulfils the requirement for trouble-free grid disconnection.

· **Microcontroller**

As well as system management, the efficient microcontroller undertakes additional tasks, such as saving data and communication.

· **LCD display**

Important information for the operator about the system operation and status is displayed on an LCD display of 2 x 16 characters.

· **RS 485 and RS 232 interfaces**

The two RS 485 and RS 232 interfaces installed as standard serve for communication with the solar inverter and the PV system. The system can be visualised via the Sunways NT Monitor software.

· **Sensor interface**

An irradiation sensor with integrated temperature sensor can be optionally connected to the relevant interface. This allows first time users to quickly grasp the mode of functioning of their PV system, and facilitates monitoring of the PV system for professionals.

· **AFI universal sensitive residual current device**

The universal (DC and AC) sensitive residual current device (AFI) monitors the solar system for residual currents. To do this, it disconnects the solar inverter from the grid by means of a relay as soon as a residual current occurs on the PV generator side or on the AC side in the solar inverter. After cutoff by the relay and as soon as the residual current has stopped, the AFI automatically attempts to reconnect the solar inverter to the grid. The AFI of the Sunways solar inverter complies with standard DIN V VDE V 0126-1-1.

In addition, the AFI of Solar Inverters NT 6000, NT 5000, NT 4000 and NT 2600 has an absolutely time-independent

effective value cutoff threshold. The solar inverter is switched off and isolated from the grid in the case of an error current of ≥ 300 mA.

- **MPP control**

The solar inverter has a rapid MPP control, which maintains the MPP point with a very high adaptation efficiency. If surplus power is provided by the PV generator, the solar inverter limits this by shifting the working point of the characteristic curve of the PV generator, so as not to exceed the maximum permissible AC feed-in power in accordance with VDEW.

Block diagram of the solar inverter in the PV system

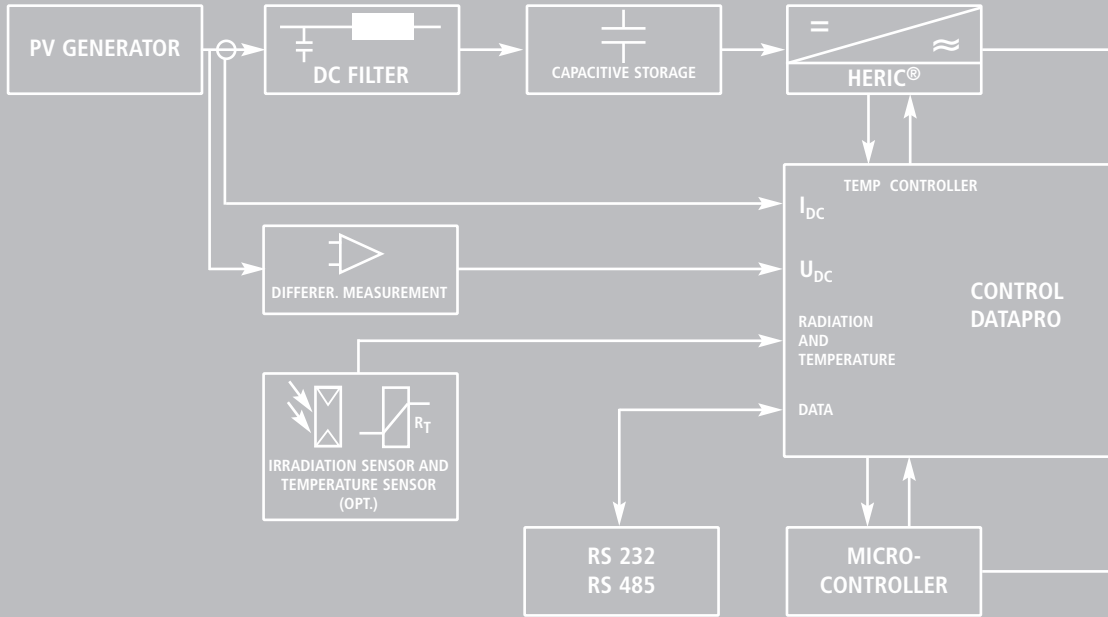

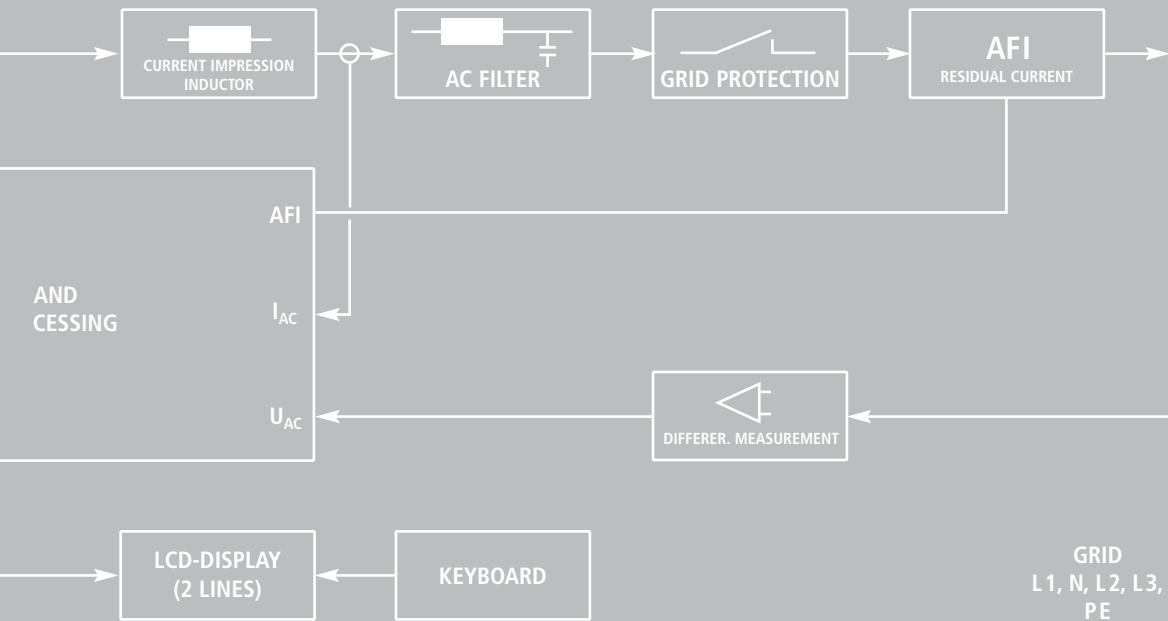

Tyco Solarlok connector



The Tyco Solarlok connectors are only approved for connection to permanently laid cables!

They must not be disconnected under load!

The circuit must be interrupted at a suitable point! The cables must be provided with a suitable adhesive label close to the Tyco Solarlok connector!

The Tyco Solarlok connectors must always be disconnected from other voltage sources on all sides during assembly, in order to protect against electric shock.



(Fig.) Manual crimping tool for assembly of Tyco Solarlok connectors

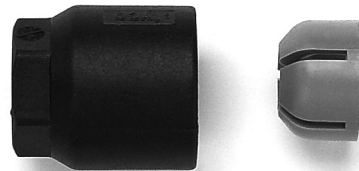

(Fig.) Tyco Solarlok connectors

Any type of soiling (dust, humidity etc.) will negatively affect the operation of the system over the desired period of use. This applies particularly for the usability of the seals and crimping of the contacts. The utmost care must therefore be taken to work cleanly during installation.

Different circular contacts are used for different conductor cross-sections for the Tyco Solarlok connectors. The correct tool insert must be used, depending on this cross-section. The enclosed Tyco Solarlok connectors are equipped with circular contacts for a cable cross-section of 4 mm. The enclosed seals have internal dimensions of 6 (for cables of 5.3 to 6.2 mm sheath diameter) and 8 mm (for cables of 7.2 to 8.0 mm sheath diameter). The seal must be matched to the sheath diameter of the cables used.



The following sequence must be observed for assembly of Tyco Solarlok connectors:

1. Strip the voltage-free cable by 8 mm.
2. Crimp on the circular contact.
3. Push the cable gland, clamping piece and seal onto the cable.
4. Engage the contact in the connector housing.
5. Screw on the clamping nut.
6. Tightening torque of the threaded cable gland is 1.5 Nm.

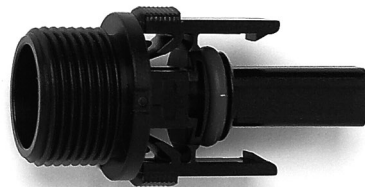

Declaration of Conformity as per EG Low Voltage Guidelines 73/23/EWG, attachment III B

We herewith declare that the following product including the required accessories has been manufactured according to the EG guidelines 73/23/EWG and 93/68/EWG:

Product	Solar Inverter	
Manufacture	Sunways AG, Photovoltaic Technology Macairestr. 3-5, D - 78467 Konstanz	
Type	Sunways NT 6000, NT 5000, NT 4000, NT 2600	
From date of manufacture	2005-05-02	
Applied standards	Standard	EN 50178
	Title	Electronic equipment for use in power installations
	Edition	1998

Explanation

This product is a component intended for further assembly. Due to the features resulting therefrom, the product cannot initially meet requirements made of finished products, machines or plants. It must thus be used for mounting / assembly only.

An evaluation of electrical and mechanical safety and of environmental conditions (e.g. extrinsic objects and / or humidity) must be performed after mounting / assembly in the finished plant.

The EMC characteristics of this product can change in a mounted / assembled state. An EMC check must thus be made for the PV-System by the manufacturer of the PV-System.

Konstanz, 2005-03-05

City, Date



Roland Burkhardt, CEO

Declaration of Conformity as defined by the EMC guideline 89/336/EWG with revisions 91/263/EWG and 93/68/EWG.

We herewith declare that the following product has been manufactured according to the requirements outlined in the EG requirements on 89/336/EWG (EMC guideline with revisions 91/263/EWG)

Product	Solar Inverter
Manufacturer	Sunways AG, Photovoltaic Technology Macairestr. 3-5, D - 78467 Konstanz
Type	Sunways NT 6000, NT 5000, NT 4000, NT 2600
from date of manufacture	2005-05-02
applied standards	Standard EN 50082-2 (EN 61000-4-2, -4-3, -4-4, -4-6, -4-8) EN 55014-1; EN 55011; EN 61000-3-2; EN 61000-3-3; E DIN VDE 0126-1-1

Explanation

Maintaining the EMC guideline assumes an EMC adapted installation of the component within the plant or the machine. Please pay attention to the installation notes of the technical specifications. Tests were carried out using a typical construction in a test assembly that conforms with the stands. The legal requirements with regard to resistance to interference and to emission of interference, limit values and standards are outlined in the above mentioned documentation. These Sunways products are intended for installation into a PV-System. The test results are not applicable to every installed state in every PV-System. This declaration therefore does not guarantee the EMC characteristics of the end product.

Konstanz, 2005-03-05

City, Date



Roland Burkhardt, CEO

Declaration of Conformity of nominal power and maximum output power of solar inverters.

Product	Solar Inverter			
Manufacturer	Sunways AG, Photovoltaic Technology Macairestr. 3-5, D - 78467 Konstanz			
Type Sunways	NT 6000	NT 5000	NT 4000	NT 2600
Nominal power S_N	4,6 kVA	4,0 kVA	3,3 kVA	2,2 kVA
Maximum output power $S_{\max10\text{Min}}$	5 kVA	4,2 kVA	3,3 kVA	2,2 kVA
$S_{\max10\text{Min}}/S_N$	1,08	1,05	1	1

Explanation

The maximum output power of the solar inverter has to be declared as a max. 10 minute average.

Konstanz, 2005-22-03

City, Date



Roland Burkhardt, CEO

Declaration of Conformity as defined by the guidelines for connection and grid feeding in parallel of in-plant generation on low-voltage-guidelines (VDEW 4. Edition 2001).

We herewith declare that the following product has been manufactured according to the requirements outlined in the guidelines for connection and grid feeding in parallel of in-plant generation on low-voltage-guidelines:

Product	Solar Inverter	
Manufacturer	Sunways AG, Photovoltaic Technology Macairestr. 3-5, D - 78467 Konstanz	
Type	Sunways NT 6000, NT 5000, NT 4000, NT 2600	
From date of manufacture	2005-05-02	
Applied standard	Standard	
	Title	In-plant generation on low-voltage-guidelines
	Edition	4. Edition 2001

Explanation

The NT series of solar inverters from Sunways are monophasic inverters that are not capable of isolated operation. They are equipped with a voltage monitor and three phase monitoring of the line voltage for undervoltage in accordance with section 2.4.2 of the VDEW Guideline (4th edition 2001). A constantly accessible isolation point is therefore not required (see section 2.1.2 Switching point with isolating function). Observation of the cut-off values of the three-phase undervoltage protection is undertaken by means of a routine check test on each device

Konstanz, 2005-22-03

City, Date



Roland Burkhardt, CEO

General exclusion of liability

Although the accuracy and completeness of the information contained in these instructions have been checked with the utmost care, no liability can be accepted for errors or omissions.

- Sunways AG reserves the right to modify the hardware and software features described here at any time, without prior notice.
- These instructions may not be duplicated, passed on, copied or translated in to other languages, either in whole or in part, in any form or by any means, without prior written permission of Sunways AG.
- Sunways AG does not provide any warranty for damages due to defective or lost data, incorrect operation or malfunctioning of the solar inverter, the software, additional equipment or PCs.

All rights reserved. © Sunways AG

The products specified in the title are copyright-protected and are sold with licences. No part of this document may be reproduced in any form, without prior written permission of Sunways AG and the Sunways licensors.

Registered trademarks

Sunways Sunways NT 6000, NT 5000, NT 4000 and NT 2600 and the Sunways logo are registered trademarks of Sunways AG, Constance.

HERIC® is a registered trademark of Fraunhofer, Munich.

Sunways AG
Photovoltaic Technology
Macairestraße 3 - 5
D - 78467 Konstanz
Telefon +49 7531 996770
Fax +49 7531 99677444
E-Mail info@sunways.de
www.sunways.de

Technische Hotline +49 7531 99677577

Sunways
Photovoltaic Technology